

System description		1
Individual Units	Pre-Filters	2
	Micro-Filters	3
	Activated-Charcoal-Filters	4
Combinations		5
Accessories and Main spare parts		5
Service Units G^{1/4}	Pre-Filter – Micro-Filter – Regulator	6
Special Filter combination G^{1/2}		
microair		7

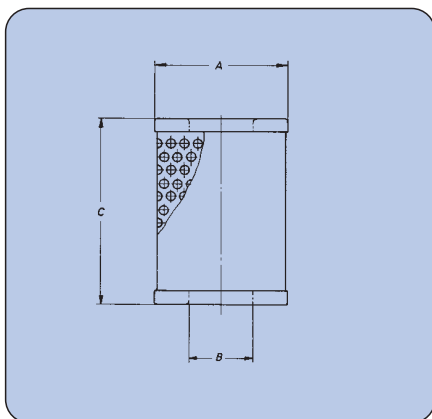
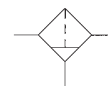

Dimensions

Size	I1	I2	II1	II2	II3	II4
A	48		71			
B	24	(12)	48		(12)	
C	75	145	110	210	310	500

Compressed-air treatment for the most critical requirements

Cleaning of compressed air with standard filters is insufficient for many applications. For cases of this kind, the filter system V-M-A, available as single units or combinations, offers a wide range of filters to meet all requirements, from technical-clean air working equipment via process air to odour-free air for breathing. Housing assembled from **V-M-A modular system** for direct flange mounting with sizes I and II. Two sizes of housing and 6 different sizes of filter element. Connecting threads from G¹/₄ to G2 in accordance with DIN-ISO 228. Housings and bowls are made of aluminium, plastic-coated or anodised, protected against corrosion, attractive appearance, easy to clean.

Differential pressure gauges. Indicates the pressure drop in filters. We recommend that the filter element is changed when the pressure drop exceeds 0,6 bar (red zone). Full exploitation of service life of filter saves money-timely replacement stops wastage of energy. Gauges can be fitted as desired to be readable from front or rear (double scale).

Kit for bracket mounting of single units and combinations available as an accessory.

Filter elements. For every size of filter-three different elements of identical dimensions. See following pages for detailed description.

Fully automatic drain valve. Fitted as standard to pre-filters and micro-filters. Mounted outboard, easily accessible for maintenance. Minimum operating pressure 4 bar.

Manually-operated drain valve. Fitted as standard in the form of a drain screw in the case of activated charcoal-filters, since these are not subject to condensation.

Single units

Pre-filters, Micro-filters, Activated-charcoal-filters

The **structure** of the V-M-A range as regards individual sizes and connecting threads is as follows: Two different sizes of housing are available with two or four different bowl lengths, which makes a total of 6 different nominal sizes or element sizes. For each size, two different connection threads are available (even three for the smallest sizes), thus making a total of 13 different versions of each single unit or combination. The **relationship** between filter size and connecting thread is shown in the table below:

Housing size	I				II							
Nominal size	I 1		I 2		II 1		II 2		II 3		II 4	
Connecting thread	G ¹ / ₄	G ³ / ₈	G ¹ / ₂	G ³ / ₄	G1	G1 ¹ / ₄	G1 ¹ / ₂	G2				

Combinations

Pre-filter - micro-filter

Micro-filter - activated-charcoal-filter

Pre-filter - micro-filter - activated-charcoal-filter

Combinations are assembled from single units in the case of sizes I and II by simple flange-mounting, using four tapered sleeves with screws and nuts. The working sequence for flange mounting is as follows:

1. Lay the first unit on the table, with the flange face uppermost.
2. Insert the sealing ring and four nuts into the appropriate recesses.
3. Position the next unit with its flange face downwards.
4. Fit the tapered sleeves one at a time and tighten the screws lightly.
5. Fully tighten the screws, working crosswise.

Operation: As a protection of the differential pressure gauge the unit must be charged **slowly** with pressure after assembly, so that a pressure equalization persists.

Filter elements

The three different filter elements available for each size of filter have identical dimensions:

V Pre-filter element - sintered Polyethylen, chiefly for filtering of solid matter.

M Micro-filter element - borosilicate glass microfiber, chiefly to remove aerosols.

A Activated-charcoal-filter element - for adsorption of oil vapours.

Since the flow direction with pre-filters and micro-filters or activated-charcoal-filters is different, attention must be paid to this when changing filter elements or reassembling filters.

The service life of filters up to the recommended time for replacement (when the pressure drop reaches 0,6 bar) is about 2000 hours of operation, depending on the incidence of contamination. We recommend a flow rate of between 10% and 80% of the specified nominal values.

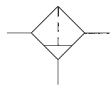

Filter elements made out of sintered Polyethylen with high capacity .

Application. Pre-filters for use with micro-filters and combinations of micro-filters/activated-charcoal-filters, and as after-filters for adsorptive, absorptive and refrigerating dryers, dust filters for compressed air and other compressed gases.

Efficiency 99,99% referred to 2µm (solid contamination)

Flow direction from inside to outside.

Structure

1. Polyethylencylinder
2. End caps aluminium

Mode of operation. As the compressed air enters the housing, the increased cross-section and the resulting reduction in velocity cause larger solid and liquid impurities to separate out and drop into the bowl. All contamination with a particle size of greater than 2µm is retained on the large-area surface of the starshaped folded filter material. The high capacity of the filter ensures a long service life.

Cleaning should if possible be carried out by washing the filter with a warm soap solution and blowing it out from the inside to the outside. Cleaning should be carried out at the latest when the pressure drop reaches 0,6 bar, i.e. the pressure-gauge pointer enters the red zone.

Technical Data

Max. operating pressure	16 bar
Operating temperature	+5°C to +80°C
Mounting position	vertical
Direction of flow	arrow
Connection thread	G ^{1/4} to G2 (see table)
Minimum operating pressure (manually-operated drain valve)	up 0 bar
(external-automatic drain valve A)	4 bar
Differential pressure gauge	0 to 2 bar (0 to 29 psi)
Efficiency	99,99% referred to 2 µm

Pre-Filters

with differential pressure gauge and add-on automatic drain valve A

Size	Thread	Unit	Element
I1	G ^{1/4} *	429.2102	429/152
	G ^{3/8} *	429.2104	429/152
	G ^{1/2} *	429.2106	429/152
I2	G ^{1/2} *	429.2206	429/156
	G ^{3/4}	429.2208	429/156
II1	G ^{3/4} *	429.2308	429/158
	G1*	429.2309	429/158
II2	G1*	429.2409	429/159
	G1 ^{1/4} *	429.2410	429/159
II3	G1 ^{1/4} *	429.2510	429/161
	G1 ^{1/2} *	429.2511	429/161
II4	G1 ^{1/2} *	429.2611	429/162
	G2	429.2612	429/162

special option - how to order:

429.x102

2	- with differential pressure gauge
5	- without differential pressure gauge

For example:

429.2102 without differential pressure gauge = **429.5102**

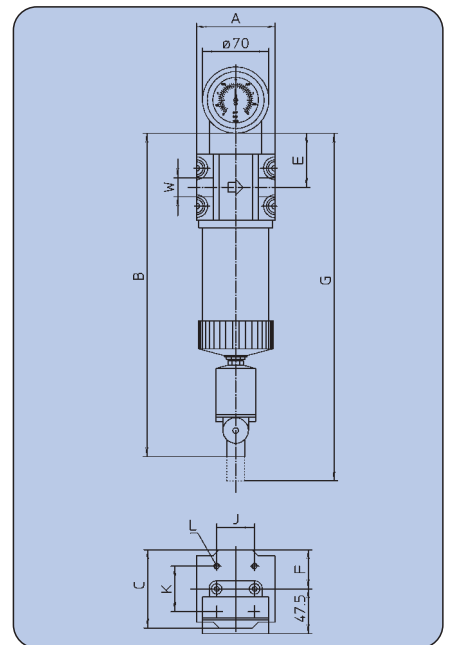
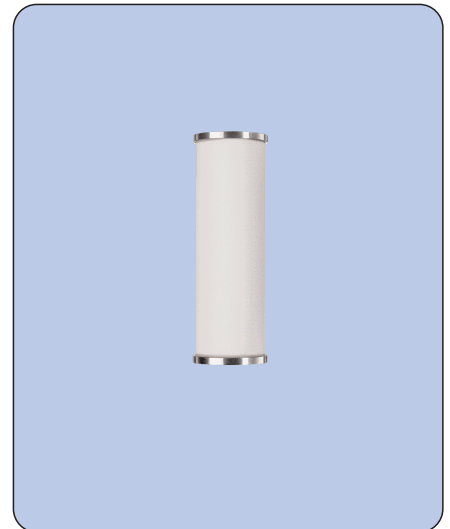

Rates of flow

Size	Thread	W	Q**
I1	G ^{1/4} , G ^{3/8} , G ^{1/2}	60	(1000)
I2	G ^{1/2} , G ^{3/4}	120	(2000)
II1	G ^{3/4} , G1	180	(3000)
II2	G1, G1 ^{1/4}	320	(5333)
II3	G1 ^{1/4} , G1 ^{1/2}	500	(8333)
II4	G1 ^{1/2} , G2	800	(13333)

** Rates of flow in Nm³/h (NI/min) measured at p₁=6 bar and Δp= 0,05 bar.

Dimensions

Size	Thread	Unit Dimensions [mm]						Mounting			Weight [g]
		A	B	C	E	F	G***	J	K	L	
I1	G ^{1/4} *, G ^{3/8} *, G ^{1/2} *	83	335	83	57	41,5	410	40	48	M6	2100
I2	G ^{1/2} *, G ^{3/4}	83	405	83	57	41,5	550	40	48	M6	2300
II1	G ^{3/4} *, G1*	118	420	118	72	59	530	70	80	M8	4800
II2	G1*, G1 ^{1/4} *	118	520	118	72	59	730	70	80	M8	5300
II3	G1 ^{1/4} *, G1 ^{1/2} *	118	620	118	72	59	930	70	80	M8	5700
II4	G1 ^{1/2} *, G2	118	810	118	72	59	1310	70	80	M8	6400

***Space required to change element.

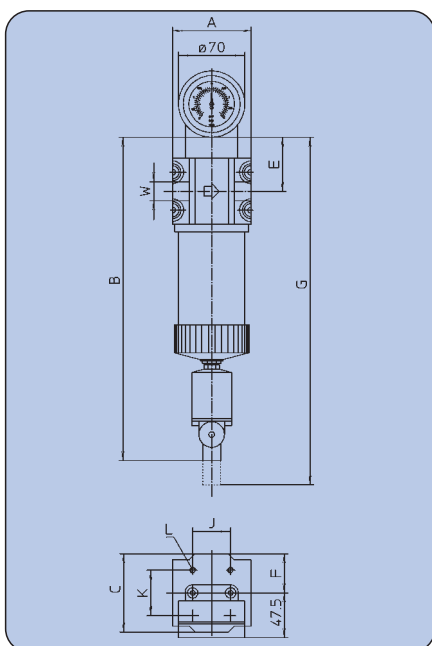
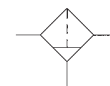

Rates of flow

Size	Thread W	Q**
I1	G ¹ / ₄ , G ³ / ₈ , G ¹ / ₂	78 (1300)
I2	G ¹ / ₂ , G ³ / ₄	120 (2000)
II1	G ³ / ₄ , G1	245 (4080)
II2	G1, G1 ¹ / ₄	275 (4580)
II3	G1 ¹ / ₄ , G1 ¹ / ₂	390 (6500)
II4	G1 ¹ / ₂ , G2	540 (9000)

** Rates of flow in Nm³/h (NI/min) measured at p₁=6 bar and Δp=0,1 bar.

Dimensions

Size	Thread W	Unit Dimensions [mm]						Mounting			Weight [g]
		A	B	C	E	F	G***	J	K	L	
I1	G ¹ / ₄ *, G ³ / ₈ *, G ¹ / ₂ *	83	335	83	57	41,5	410	40	48	M6	2100
I2	G ¹ / ₂ *, G ³ / ₄	83	405	83	57	41,5	550	40	48	M6	2300
II1	G ³ / ₄ *, G1*	118	420	118	72	59	530	70	80	M8	4800
II2	G1*, G1 ¹ / ₄ *	118	520	118	72	59	730	70	80	M8	5300
II3	G1 ¹ / ₄ *, G1 ¹ / ₂ *	118	620	118	72	59	930	70	80	M8	5700
II4	G1 ¹ / ₂ *, G2	118	810	118	72	59	1310	70	80	M8	6400

***Space required to change element.

Borosilicate glass microfiber filters. Used mainly to filter out aerosols and solid contamination with a particle size of over 0,01µm. We recommend that a pre-filter V is fitted upstream.

Application. Paint-spraying, sandblasting, control systems, vacuum systems, measuring instruments, fluids, air for conveying devices, process air, aircushion bearings, air-conditioning systems.

Efficiency 99,9999% referred to 0,01 µm. Residual oil content 0,01 ppm.

Flow direction from inside to outside.

Structure

1. Inner support, perforated stainless steel.
2. Pre-filtration mesh.
3. Borosilicate glass microfiber material.
4. Support fabric.
5. Outer support, perforated stainless steel.
6. Foam-material sheath.
7. End caps aluminium.

Mode of operation. Air, which should if possible be pre-cleaned (pre-filter), flows through the filter element from the inside to the outside. Coarse particles are first removed by the pre-filtration mesh, and fine filtration is then provided by the multi-layer borosilicate glass microfiber material. The high void content of 94% between the glass fibres ensures a high capacity for solid particles. **Cleaning** is not possible. The filter elements should be replaced at the latest when the pressure drop reaches 0,6 bar, i.e. the differential pressure-gauge pointer enters the red zone respectively after about 2000 hours of operation.

Technical Data

Max. operating pressure	16 bar
Operating temperature	+5°C to +80°C
Mounting position	vertical
Direction of flow	arrow
Connection thread	G ¹ / ₄ to G2 (see table)
Minimum operating pressure (manually-operated drain valve)	up 0 bar
(external-automatic drain valve A)	4 bar
Differential pressure gauge	0 to 2 bar (0 to 29 psi)
Efficiency	99,9999% referred to 0,01 µm
Residual oil content	0,01 ppm

Micro-Filters with differential pressure gauge and automatic drain valve A

Size	Thread	Unit	Element
I1	G ¹ / ₄ *	430.2102	430/2
	G ³ / ₈ *	430.2104	430/2
	G ¹ / ₂ *	430.2106	430/2
I2	G ¹ / ₂ *	430.2206	430/6
	G ³ / ₄	430.2208	430/6
II1	G ³ / ₄ *	430.2308	430/8
	G1*	430.2309	430/8
II2	G1*	430.2409	430/9
	G1 ¹ / ₄ *	430.2410	430/9
II3	G1 ¹ / ₄ *	430.2510	430/11
	G1 ¹ / ₂ *	430.2511	430/11
II4	G1 ¹ / ₂ *	430.2611	430/12
	G2	430.2612	430/12

special option - how to order:

430.x102

- 2 - with differential pressure gauge
 5 - without differential pressure gauge

For example:

430.2102 without differential pressure gauge = 430.5102

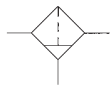

Activated-charcoal-filters for the adsorption of liquid vapours. We recommend that a micro-filter M is fitted upstream in all cases where dried air is not used.

Application. Food industry, packing industry, beverage industry, air for breathing, pressure chambers, medicinal technology, dental technology.

Efficiency Residual oil content 0,005 ppm.

Flow direction from inside to outside.

- Structure**
1. Activated-charcoal layer.
 2. Filtration layer.
 3. Support sheath, perforated stainless steel.
 4. End caps aluminium.

Mode of operation. The pre-cleaned compressed air (from a dryer, micro-filter or micro-filter with pre-filter) first flows through the activated-charcoal layer. The thickness of this layer ensures a sufficient contact time for the adsorption of liquid vapours. Any carried-over activated-charcoal particles are retained in the outer filter layer. In order to ensure a long service life for the filter, the compressed air which enters the activated-charcoal filter should not contain any solid or liquid contamination.

Cleaning or regeneration is not possible. The filter elements should be replaced at the latest after about 2000 hours of operation.

Technical Data

Max.operating pressure	16 bar
Operating temperature	+5°C to +80°C
Mounting position	vertical
Direction of flow	arrow
Connection thread	G ^{1/4} to G2 (see table)
Differential pressure gauge	0 to 2 bar (0 to 29 psi)
Residual oil content	0,005 ppm

Activated-Charcoal-Filters

Without differential pressure gauge but with manually-operated drain valve

Size	Thread	Unit	Element
I1	G ^{1/4} *	431.6102	431/2
	G ^{3/8} *	431.6104	431/2
	G ^{1/2} *	431.6106	431/2
I2	G ^{1/2} *	431.6206	431/6
	G ^{3/4}	431.6208	431/6
II1	G ^{3/4} *	431.6308	431/8
	G1*	431.6309	431/8
II2	G1*	431.6409	431/9
	G1 ^{1/4} *	431.6410	431/9
II3	G1 ^{1/4} *	431.6510	431/11
	G1 ^{1/2} *	431.6511	431/11
II4	G1 ^{1/2} *	431.6611	431/12
	G2	431.6612	431/12

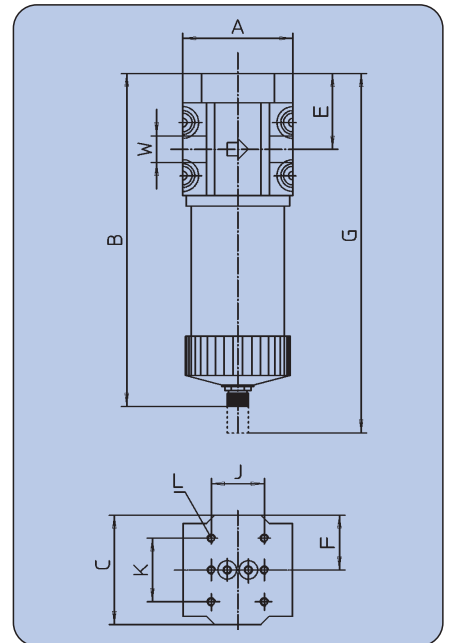
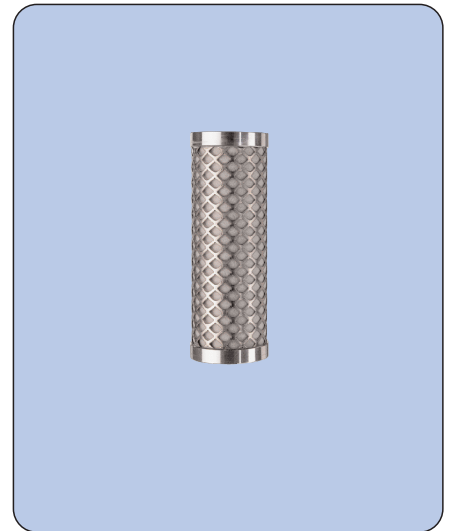

Rates of flow

*Size	Thread	W	Q**
I1	G ^{1/4} *, G ^{3/8} *, G ^{1/2} *	30	(500)
I2	G ^{1/2} *, G ^{3/4}	60	(1000)
II1	G ^{3/4} , G1	90	(1500)
II2	G1, G1 ^{1/4}	160	(2667)
II3	G1 ^{1/4} , G1 ^{1/2}	250	(4167)
II4	G1 ^{1/2} , G2	400	(6667)

** Rates of flow in Nm³/h (NI/min) measured at p₁=6 bar and Δp=0,12 bar.

Dimensions

Size	Thread	Unit Dimensions [mm]						Mounting			Weight [g]
		W	A	B	C	E	F	G***	J	K	
I1	G ^{1/4} *, G ^{3/8} *, G ^{1/2} *	83	245	83	57	41,5	320	40	48	M6	1890
I2	G ^{1/2} *, G ^{3/4}	83	315	83	57	41,5	460	40	48	M6	2090
II1	G ^{3/4} *, G1*	118	330	118	72	59	440	70	80	M8	4590
II2	G1*, G1 ^{1/4} *	118	430	118	72	59	640	70	80	M8	5090
II3	G1 ^{1/4} *, G1 ^{1/2} *	118	530	118	72	59	840	70	80	M8	5490
II4	G1 ^{1/2} *, G2	118	720	118	72	59	1220	70	80	M8	6190

***Space required to change element.

Drain valves, see individual brochures 7 page 1 and 2

* Inlet and outlet reduced

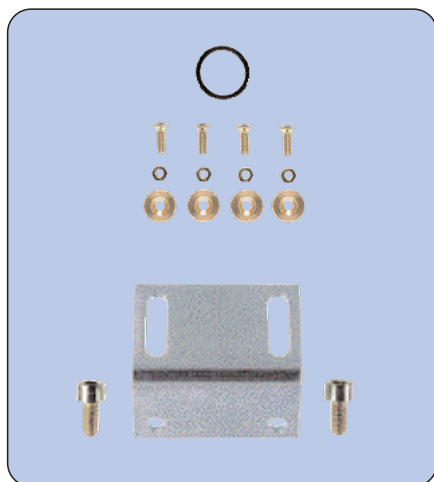
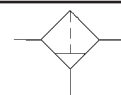

Combinations

Pre-filter / micro-filter

V-M

Micro-filter / activated-charcoal-filter

M-A

Pre-filter / micro-filter / activated-charcoal-filter

V-M-A

Size	Thread	V-M	M-A	V-M-A
I1	G ¹ / ₄ *	432.2102	433.2102	434.2102
	G ³ / ₈ *	432.2104	433.2104	434.2104
	G ¹ / ₂ *	432.2106	433.2106	434.2106
I2	G ¹ / ₂ *	432.2206	433.2206	434.2206
	G ³ / ₄	432.2208	433.2208	434.2208
II1	G ³ / ₄ *	432.2308	433.2308	434.2308
	G1*	432.2309	433.2309	434.2309
II2	G1*	432.2409	433.2409	434.2409
	G1 ¹ / ₄ *	432.2410	433.2410	434.2410
II3	G1 ¹ / ₄ *	432.2510	433.2510	434.2510
	G1 ¹ / ₂ *	432.2511	433.2511	434.2511
II4	G1 ¹ / ₂ *	432.2611	433.2611	434.2611
	G2	432.2612	433.2612	434.2612

special option - how to order:

432.x102

- 2 - with differential pressure gauge
5 - without differential pressure gauge

For example:

432.2102 without differential pressure gauge = 432.5102

Accessories

Connectors for sizes I and II for flange connection of two units. Kit consists of one sealing ring and four tapered sleeves, screws and nuts. Two kits are required for the flange connection of three units.

Kit for bracket mounting for mounting on vertical surfaces. Consists of a mounting bracket and two screws to secure this to the unit, at the front or rear as desired.

	Size I	Size II
Connectors		
- Kit	429/29	429/33
Bracket mounting		
- Kit	429/25	429/27
Special wrench	429/70	429/92

Special wrench (without picture) for dismounting the bowls.

Main spare parts

Differential pressure gauges for all filters. Two-part scale 0 to 2 bar (0 to 29 psi). Green zone 0 to 0,6 bar, red zone 0,6 to 2 bar. Complete with mounting components for flange mounting (2 screws, 2 seals).

Differential pressure gauge	5429.10	5429.10
-----------------------------	---------	---------

Rates of flow / Dimensions

**Rates of flow in Nm³/h (NI/min) measured at p₁=6 bar and Δp=0,12 bar.

Size	Thread	Rates of flow Q**	Installation length [A]	
			V-M / M-A	V-M-A
I1	G ¹ / ₄ *, G ³ / ₈ *, G ¹ / ₂ *	30 (500)	166	249
I2	G ¹ / ₂ *, G ³ / ₄	60 (1000)		
II1	G ³ / ₄ *, G1*	90 (1500)	236	354
II2	G1*, G1 ¹ / ₄ *	160 (2667)		
II3	G1 ¹ / ₄ *, G1 ¹ / ₂ *	250 (4167)		
II4	G1 ¹ / ₂ *, G2	400 (6667)		

For further technical data, see individual units.

Drain valves, see individual brochures 7 page 1 and 2.

Service units

Air preparation by means of Pre-Microfilter with regulator for measurement devices.

Flow rate at 1 bar (Δp 0,2 bar) 200 NI/min.

Article	Order-No.
Combination G^{1/4} (Pre - Microfilter - Regulator) without differential pressure gauge, with automatic drain valves, Bracket mounting inclusive, Regulator with gauge (range 0,5 - 3 bar) adjusted at 1 bar.	432.017

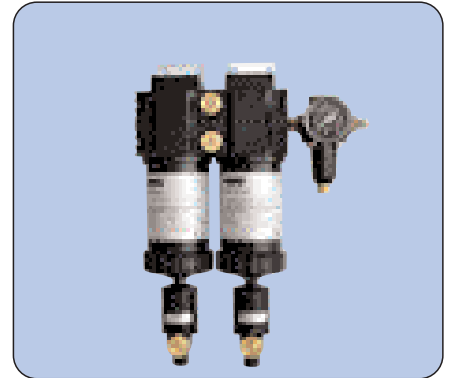

Combination G^{1/4} (Pre - Microfilter - Regulator) with differential pressure gauge for microfilter, with automatic drain valves, Bracket mounting inclusive, Regulator with gauge (range 0,5 - 3 bar) adjusted at 1 bar.	432.002
--	---------



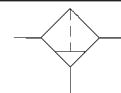

Filter-regulating station for paint-spraying Air quality according to ISO 8573.1 - Class 1

Multi-stage compressed air preparation system with high-quality filter elements (pre-filter, micro-filter and, if needed, activated carbon-filter) for optimal paint results, avoiding (rendering unnecessary) costly retouching work and preventing operational failure. Removes contamination such as H₂O, CO, CO₂, hydrocarbons and dust particles. High flow-rate (3000NI/min) with differential pressure gauge as an individual indicator of the degree of contamination. Provides optimal economic efficiency, service and safety.

Technical Data

Thread	G ¹ / ₂
Primary pressure	16 bar
Temperature range	+5°C bis +80°C
Flow rate	3000 NI/min
Washers	NBR
Materials	Housing Al, CuZn39Pb3 Distributor, bowl - Plastic (coated)

Additional applications:

Sand blasting
Chemical industry
Synthetics industry
Production of paints and varnishes
Packaging industry
Technical specification subject to prior change

Stage One - Pre-filter with Automatic Drain Valve

Finely sintered bronze filter, 5µm filtration, for filtering solids and liquids, filtration efficiency 99%, (reusable after washing)

Stage Two - Pressure Reducer gauge with solvent resistant glass protecting panel

Independent of primary pressure with increased precision, without air consumption, regulates the desired operating pressure from 0,5 to 10 bar.

Stage Three - Micro filter

Multi-layered deep-bed filter with three-dimensional filtration by borosilicate fibrous web with high-capacity dirt-absorption. For fine filtration of solid particles in compressed air and oil-water aerosols up to a residual oil content of 0,01mg/m³. Chemically and biologically inactive, water-resistant. Stainless steel protective case and aluminium cover. Filtration efficiency 99,99998% at 0,01µm
Tested and approved according to LPV 0.700.9900 (Fraunhofer Institute)

Article Number	Unit
Filter regulating station with 2 ball valves (G ³ / _a)	439.2
Filter regulating station with 2 couplings DN 7,2	439.3

Bracket mounted

Supplementary element: activated carbon filter + distributor block with two outlets can be connected to 439.2 and to 439.3 with double nipple 185.77.

Stage Four - activated carbon filter

Breathing-air quality according to DIN 3188 with significantly less contamination than the surrounding air (differential pressure gauge as an option!)

Multi-layered activated carbon for the absorption of vaporized liquids and hydrocarbons (oil-aerosols, odours). Residual oil content 0,005 ppm.

Activated carbon filter + distributor with 2 outlets	439.4
--	-------

Main spare parts

Pre-filter element	429/100
Micro-filter element	430/6
Activated-charcoal-filter element	431/6
Pressure gauge Ø 50, 0 - 16, vertical	102
Pressure gauge Ø 63, 0 - 16, horizontal	89